

French Company seeking urgently a supplier agreement for the Assembly and Finishing of Luxury High End Paper/Cardboard Bifold Wallets (Large Production Volumes)

Summary

Profile type

Business request

Company's country

France

POD reference

BRFR20260416009

Profile status

PUBLISHED

Type of partnership

Supplier agreement

Targeted countries

• All countries

Contact Person

[Enrico FRANZIN](#)

Term of validity

16 Apr 2026**16 Apr 2027**

Last update

16 Apr 2026

General Information

Short summary

French Company seeking urgently a supplier agreement for the assembly and finishing of Luxury High End Paper/Cardboard Bifold Wallets (Large Production Volumes : Target capacity: 750,000–1,000,000 units/year;) with a Preference for Eastern European Suppliers

Full description

The French industrial company is specialised in high value printed packaging and the assembly of premium paper and cardboard components operates under strict quality standards to deliver luxury grade finishes. The company combines an agile industrial organisation with strong know how in high end production. It is also strongly committed to CSR, with a focus on eco design, responsible sourcing and sustainable manufacturing practices.

The SME is seeking a subcontractor for the assembly and finishing of a luxury bifold wallet made of paper/cardboard. The product is composed of four components supplied by the client. The targeted production volume is 750,000 to 1,000,000 units per year, organised in batches of approximately 150,000 units, with a lead time of one month per batch. The project involves high-end luxury standards, requiring flawless finishes (no visible glue marks, bubbles, dust or defects).

The service involves: the assembly and finishing of a luxury paper/cardboard product comprising four components, supplied by the client with the exception of the grey cardboard spine (minimum thickness 0.4 mm, 6 x 80 mm), which will be supplied by the subcontractor.

The process includes cutting the corners at 45°, applying white glue over the entire surface, folding down all sides, perforating the lining/presentation material, precise positioning and final assembly in accordance with the technical drawings.

The finished products are packed into plastic bags supplied by the customer, at a rate of two units per bag.

The company is looking urgently for a supplier agreement with a preference for Eastern European suppliers without excluding those from other regions.

Advantages and innovations

Technical specification or expertise sought

- Capability to assemble paper/cardboard components with a binding state of art to luxury standards (no visible defects: glue marks, fingerprints, bubbles, dust, creases).
- Accurate cutting and turn-in operations with repeatability meeting ± 1 mm text positioning tolerances.
- Punching capability: \varnothing 2 mm holes with ± 0.5 mm positional tolerance on lining/display material.
- Precise centring and selective gluing of lining/display material with ± 0.5 mm tolerance.
- Ability to supply back material in grey board (min. 0.4 mm) sized 6 mm x 80 mm.
- Process controls to ensure oven resistance compliance: NF EN ISO 9142:2004, 85°C / 60% RH / 500 hours.
- Traceable storage and batch recording; minimum storage capacity 40 pallets under temperate, humidity-protected conditions.
- Deliver batches of up to 150,000 units/month (40,000/week), minimum run 10,000.
- Handle incoming material flows (~20 pallets every two months) and store components securely under temperate, humidity-protected conditions with traceability (40 pallets).

Stage of development

Sustainable Development goals

- **Goal 5: Gender Equality**
- **Goal 4: Quality Education**
- **Goal 8: Decent Work and Economic Growth**
- **Goal 6: Clean Water and Sanitation**
- **Goal 17: Partnerships to achieve the Goal**
- **Goal 13: Climate Action**
- **Goal 10: Reduced Inequality**
- **Goal 9: Industry, Innovation and Infrastructure**
- **Goal 12: Responsible Consumption and Production**

IPR Status

IPR Notes

Partner Sought

Expected role of the partner

Subcontractor will manufacture/prepare the back material (grey board, min. 0.4 mm, 6 mm x 80 mm) and carry out the full assembly and finishing operations of the bifold wallet using Client-supplied components, in line with the assembly plans and diagram.

The partner must:

- Meet luxury-quality criteria with strong in-process controls and clean handling.
- Commit to CSR requirements through signature of the Responsible Purchasing Charter (UN Global Compact principles).

Type of partnership

Supplier agreement

Type and size of the partner

- **SME <=10**
- **SME 11-49**
- **Big company**
- **SME 50 - 249**

Dissemination

Technology keywords

Targeted countries

- **All countries**

Market keywords

- **09004007 - Printing and binding**
- **09004006 - Packing products and systems**

Sector groups involved

- **Agri-Food**
- **Creative Industries**

Media

Images

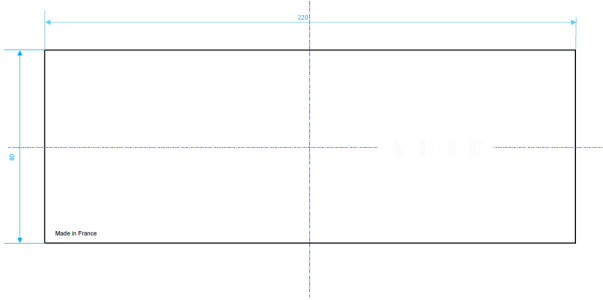

[Project Y assembled cover, exterior view drawing_0.png](#)

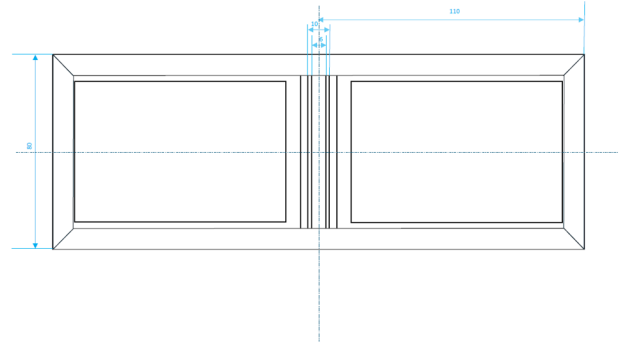

[Project Y assembled cover, interior view drawing_0.png](#)

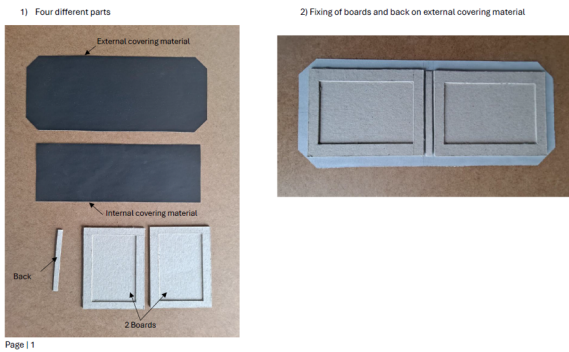

[Project Y assembly diagram_0.png](#)

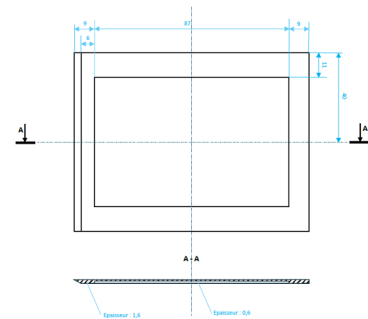

[Project Y board drawing_0.png](#)

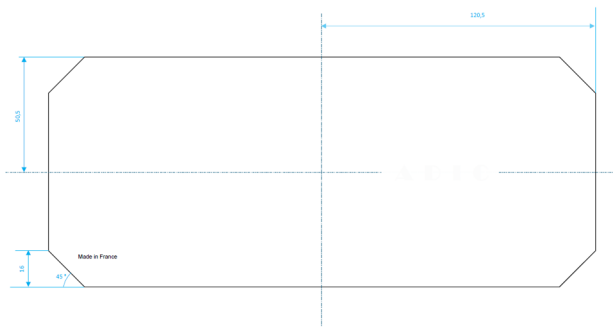

[Project Y external covering material drawing_0.png](#)

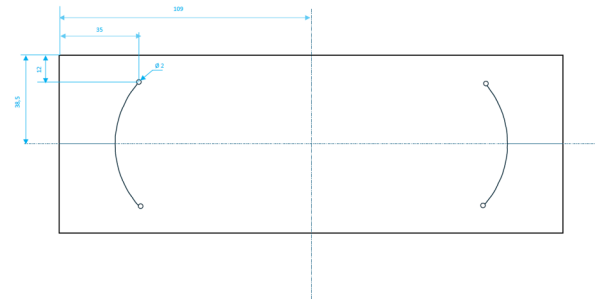

[Project Y internal covering material drawing_0.png](#)